



Multitechnology Know-how

Millenium II

logic controller



- ▶ The most complete software offer on the market
- ▶ Pre-programmed application-specific functions
- ▶ An open, adaptable configuration

More
than a standard



► **Millenium II** the logic controller that's flexible and adaptable to your applications



Millenium 2 offers a number of solutions for your applications. It's simpler than ever to incorporate automation control functions such as timing, counting, monitoring, temperature control, sequencing, etc.

Your pre-programmed functions

Millenium 2 incorporates the most extensive function library on the market, which now includes application-specific functions (calculation, pump rotation, Cam timer, etc). Moreover, Crouzet will offer to design the function which is perfect for your application.

Your open, adaptable configuration

Millenium 2 consists of a complete range with versions which are:

- user-definable from the front panel
- low-cost (no displays and parameter-setting buttons)
- bare boards for mass-production applications
- numerous extensions (I/O, communication, etc)

Your flexibility for programming

Millenium 2 is the only logic controller to combine flexible programming using function blocks with the added benefit of sequential flow chart blocks. Its user-oriented design simplifies the process of designing your programs.

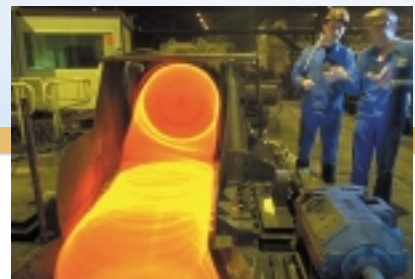

Millenium II

Positive advantages for your applications!



Machines

With Millenium 2, small machines benefit from adaptability and simplicity of installation. Exploit its communication capacities and add more functions to your devices with the greatest of ease.



Building management

With its pre-programmed function blocks, analogue inputs, and powerful calendar clock, Millenium 2 makes it easy to monitor your installations: heating, air conditioning, pumping, lighting, and access control (gates, management of safety devices, etc).



Temperature control

Software functions are included which simplify the design of your heating cycles. In addition, as your systems evolve, there will be a version of Millenium 2 to suit.

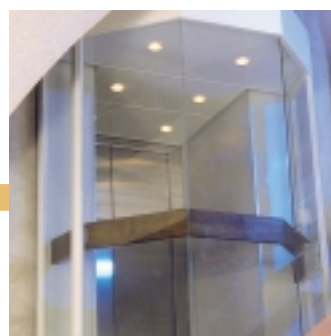

Millenium II

► The most complete software offer on the market

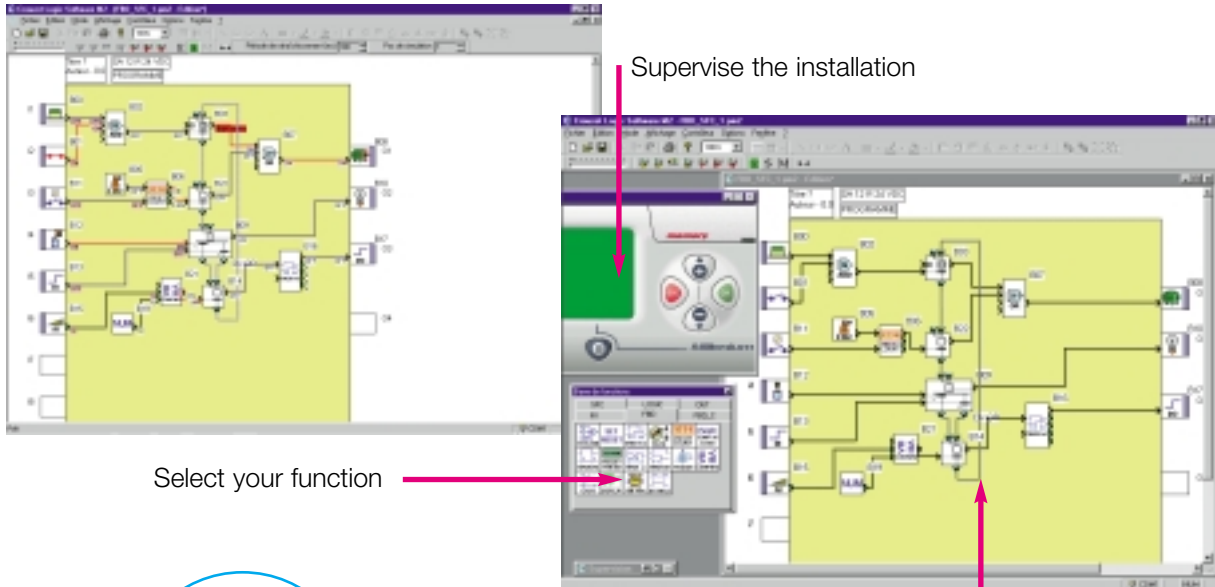

Select your function

Supervise the installation

Construct your program



The points of Millenium 2

A genuine CLS (Crouzet Logic Software) software workshop for PC:

- programming,
- simulation,
- monitoring and supervision,
- program uploading/downloading,
- customized documentation,
- automatic program compilation,
- online help.

- **Large processing capacity: 128 function blocks.**
- **Battery backup of data in the event of a power failure: 10 years.**
- **Password protection.**
- **Automation control parameters set using buttons on the front panel.**

The user-oriented design of Millenium 2 simplifies program creation by combining speed, performance and safety:

- pre-programmed functions
- application-specific functions
- proprietary functions
- FBD (Function Block Diagram) functions
- GRAFCET SFC (Sequential Function Chart) functions



Interactive CD-Rom

- CLS software workshop
- + tutorial
- + application library
- + promotional sales brochure
- + technical sales brochures



Function toolbar

► FBD functions

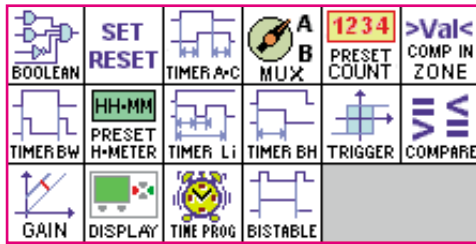

16 pre-programmed functions are available for counting, timing, comparison, multiplexing, timer programming and display.

► SFC (GRAFSET) functions

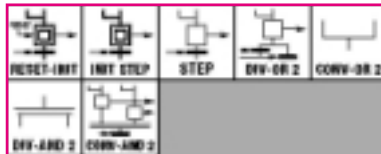

All sequential flow chart functions are incorporated, with backup or reinitialization in the event of a power failure (step, transition, divergence, convergence, etc).

► Logic functions



AND, OR, NAND, NOR, XOR, NOT functions.

► Inputs



You can connect physical inputs, whether discrete, analogue or potentiometer. There are also internal inputs such as the keypad, constants, etc.

► Outputs



You have two types of output:

- physical: discrete, solid state or PWM (Pulse Width Modulation),
- internal: display backlighting.

	BOOLEAN Used to create logic equations between connected inputs.		TIMER Li Pulse generator (ON setting, OFF setting).
	SET - RESET Bistable memory - Priority assigned to either SET or RESET.		TIMER B/H Timer. Function BH. (adjustable impulse signal).
	TIMER A/C Timer - Function A/C (On-delay and off-delay).		TRIGGER Defines an activation zone with Hysteresis.
	MUX Multiplexing functions on 2 analogue values.		COMPARE Comparison of 2 analogue values using =, >, <, ≥, ≤ operators.
	PRESET COUNT Up/down counter.		GAIN Used to convert an analogue value by changing scale and offset.
	COMP IN ZONE Zone comparison (MIN ≤ VALEUR ≤ MAX).		DISPLAY Display of digital and analogue data, date, time, messages for man-machine interface.
	TIMER B/W Timer - Function B/W (impulse on a rising or falling edge).		TIME PROG Hourly, weekly and annual programmer.
	PRESET H-METER Hour counter (presetting of hour, minute).		BISTABLE Impulse relay function.

Your applications already pre-programmed with our application-specific functions!

CROUZET offers you a library of application-specific functions which can be added to according to your requirements:

- **Calculation function**
Multiplication/Division
Addition/Subtraction
- **Data archiving function**
- **Cam timer function**
- **Clock function**
with modifiable parameters
- **Pump rotation function**
- **Up/down counter with calculation function**

Example of application-specific function:

Rotation of 3 pumps

The pump rotation function is used to manage the water level in a tank by means of 3 sensors and 3 pumps.

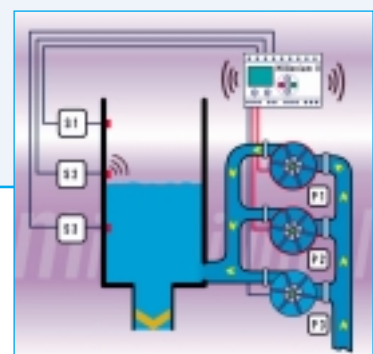

▶ An open,
adaptable configuration



Millennium II

▶ Improved design to suit your applications

Versions and extensions for you to construct your own solution

	12 Inputs/Outputs	20 Inputs/Outputs	Extensions
Type XT Expandable version with display and parameter-setting buttons			Adjacent <ul style="list-style-type: none"> • 6 Inputs/Outputs • Communication using MODBUS or AS-i protocol
Type SA Standard version with display and parameter-setting buttons			Local <ul style="list-style-type: none"> • 4 solid state outputs • Transparent communication between two XT20
Type EC Blind version without display or parameter-setting buttons			
Type CN Bare board version for mass-production applications			



Example of configuration:



Millenium II



▶ Technical characteristics

Insulation	7 MΩ
Safety class	0 industrial / II domestic casing
Earthing	None
Protection	IP20/Terminal block IP40 IP00 for CN12 and CN 20
Certification	CE, UL, cUL
Compliance	EN 60947-1 EN 60730-1 EN 60601-1
Programming method	Function blocks/SFC
Program size	128 blocks
Program memory	Flash EEPROM

Removable memory	EEPROM
Data memory	256 bits/64 words backed up for 10 years
LCD display	Display with 4 lines of 12 characters
Real-time clock	Drift < 1 min/month at 25 °C with user-definable correction of drift Data retention: 10 years (lithium battery)
Storage temperature	-40 -> +70 °C
Operating temperature	-5 -> +55 °C
Relative humidity (without condensation)	90 -> 95 %
Dimensions (w x h x d)	SA12-EC12: 72 x 90 x 60 mm SA20-XT-EC20: 125 x 90 x 60 mm CN12: 72 x 90 x 42 mm CN20: 125 x 90 x 42 mm

▶ Technical characteristics

100 ... 240 VAC power supply

Operating voltage	100 VAC -> 240 VAC (+10 % - 15 %) 50/60 Hz
Operating limits	85 VAC -> 264 VAC
Immunity from micro power cuts	10 ms
Maximum inrush current	7 A
Maximum power consumption	SA12-EC12-CN12: 6 VA SA20-EC20-CN20: 6,5 VA XT20: 8 VA

24 VAC power supply

Operating voltage	24 VAC +20 % - 15 % 50/60 Hz
Operating limits	20,4 VAC -> 28,8 VAC
Immunity from micro power cuts	10 ms
Maximum inrush current	7 A
Maximum power consumption	SA12-EC12-CN12: 6 VA SA20-EC20-CN20: 6,5 VA XT20: 8 VA

24 VDC power supply

Operating voltage	24 VDC +20 % - 15 %
Operating limits	20,4 VDC -> 28,8 VDC
Immunity from micro power cuts	1 ms
Maximum inrush current	7 A
Maximum power consumption	SA12-EC12-CN12: 3,5 W SA20-EC20-CN20: 4 W XT20: 5 W

Analogue inputs (24 VDC model only)

CN12-SA12-EC12	4 inputs from I5 to I8
CN20-SA20-EC20-XT20	8 inputs from I5 to I12
Measuring range	(0 -> 10 V) or (0 -> Power supply V)
Resolution	8 bits
Conversion time	10 ms
Max. input voltage	28,8 VDC
Input impedance (kΩ)	> 10
Precision	+/- 5 %
Temperature drift	+/- 3 LSB
Potentiometer control	2,2 KΩ / 0,5 W

100 - 240 VAC input

Input voltage	100 - 240 (+10 % / -15 %) VAC
Operating frequency	50/60 Hz
Input impedance	700 kΩ
Pull-in voltage at logic state 1	≥ 80 VAC
Drop-out voltage at logic state 0	≤ 40 VAC
Status indicator	On LCD screen for SA12, SA20, XT20

24 VAC input

Input voltage	24 (+10 % / -15 %) VAC
Operating frequency	50/60 Hz
Input impedance	4 kΩ
Pull-in voltage at logic state 1	≥ 15 VAC
Drop-out voltage at logic state 0	≤ 5 VAC
Status indicator	On LCD screen for SA12, SA20, XT20

24 VDC input

Input voltage	24 (+20 % -15 %) VDC
Input current	3,2 mA/5,5 mA max
Pull-in voltage at logic state 1	≥15 VDC
Drop-out voltage at logic state 0	≤ 5 VDC
Response time	10 ms
Sensor type	Contact - 3-wire PNP
Status indicator	On LCD screen for SA12, SA20, XT20

Relay outputs

Max. voltage breaking capacity	250 VAC
Max. current breaking capacity	8 A
Service life	8 A / 250 VAC resistive (100 000 operations)
Min. load	10 mA / 5 VDC
Response time	10 ms
Status indicator	On LCD screen for SA12, SA20, XT20

Discrete/PWM solid state outputs (24 VDC model only)

PWM solid state outputs	SA12-EC12-CN12: 01 to 04 SA20-XT20-EC20-CN20: 01 to 06
Voltage breaking capacity	5-28,8 VDC
Current breaking capacity	0,7 A / 5-28,8 VDC
Min. load	1 mA
Max. inductive load	0,7 A
Max. incandescent load	0,1 A
Off-state leakage	0,1 mA / 24 VDC

Response time	1ms
Isolated	no
PWM frequency	120 Hz to 1 920 Hz (user-definable)
PWM Cyclic ratio	0 to 100 % (256 steps)
PWM precision at 120 Hz	< 5 % (15 % to 85 %) load at 10 mA
PWM precision at 500 Hz	< 10 % (20 % to 80 %) load at 10 mA
Status indicator	On LCD screen for SA12, SA20, XT 20

▶ Starter kit

- Each kit includes:
 - a standard or expandable Millennium 2
 - a PC/Millennium 2 link interface
 - an interactive CD-Rom including the software workshop, tutorial, application library and technical brochures.



Type	Input	Output	Power supply	Code
KIT SA 12	8	4 relay	24 VDC	88 950 070
	8	4 relay	100 - 240 VAC	88 950 071
KIT SA 20	12	8 relay	24 VDC	88 950 072
	12	8 relay	100 - 240 VAC	88 950 073
KIT XT 20	12	8 relay	24 VDC	88 950 074
	12	8 relay	100 - 240 VAC	88 950 075

▶ Standard versions

- Preconfigured
- Intuitive programming via function block (FBD) or grafcet (SFC)
- Function: timing, counting, etc
- Application-specific functions: rotation, cam timers, calculation, etc
- Discrete, analogue or potentiometer inputs
- Relay, solid state or PWM outputs
- Indicator on backlit LCD display
- Program protected by a password
- Calendar program clock
- User-definable from the front panel



Type	Input	Output	Power supply	Code
SA 12	8	4 relay	24 VDC	88 950 041
	8	4 relay	100 - 240 VAC	88 950 043
	8	4 relay	24 VAC	88 950 044
	8	4 solid state/4 PWM	24 VDC	88 950 042
SA 20	12	8 relay	24 VDC	88 950 051
	12	8 relay	100 - 240 VAC	88 950 053
	12	8 relay	24 VAC	88 950 054
	12	8 solid state/6 PWM	24 VDC	88 950 052

- Standard products
- Standard products, non stocked



▶ Expandable version

- Expandable: communication, inputs/outputs, etc
- Intuitive programming via function block (FBD) or grafcet (SFC)
- Function: timing, counting, etc
- Application-specific functions: rotation, cam timers, calculation, etc
- Discrete, analogue or potentiometer inputs
- Relay, solid state or PWM outputs
- Indicator on backlit LCD display
- Program protected by a password
- Calendar program clock
- User-definable from the front panel
- Can take an XC adjacent extension and an XL local extension



Type	Input	Output	Power supply	Code
XT 20	12	8 relay	24 VDC	88 950 061
	12	8 relay	100 - 240 VAC	88 950 063
	12	8 relay	24 VAC	88 950 064
	12	8 solid state/6 PWM	24 VDC	88 950 062

▶ Blind versions

- No display or parameter-setting buttons
- Intuitive programming via function block (FBD) or grafcet (SFC)
- Function: timing, counting, etc
- Application-specific functions: rotation, cam timers, calculation, etc
- Discrete, analogue or potentiometer inputs
- Relay, solid state or PWM outputs
- Program protected by a password
- Calendar program clock



Type	Input	Output	Power supply	Code
EC 12	8	4 relay	24 VDC	88 950 021
	8	4 relay	100 - 240 VAC	88 950 023
	8	4 relay	24 VAC	88 950 024
	8	4 solid state/4 PWM	24 VDC	88 950 022
EC 20	12	8 relay	24 VDC	88 950 031
	12	8 relay	100 - 240 VAC	88 950 033
	12	8 relay	24 VAC	88 950 034
	12	8 solid state/6 PWM	24 VDC	88 950 032

▶ Bare board versions

- For mass-production applications
- Intuitive programming via function block (FBD) or grafcet (SFC)
- Function: timing, counting, etc
- Application-specific functions: rotation, cam timers, calculation, etc
- Discrete, analogue or potentiometer inputs
- Relay, solid state or PWM outputs
- Program protected by a password
- Calendar program clock

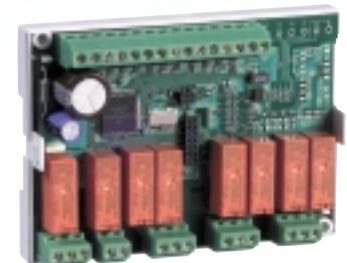

Type	
CN 12	For mass-production applications: please consult us
CN 20	For mass-production applications: please consult us

- Standard products
- Standard products, non stocked

Local extensions

- For XT 20 only (1 local extension per module)
- Millenium - Millenium local link
- Doubles the hardware and software capacities
- Transparent communication between 2 XT 20
- Max. distance between 2 XT 20: 10 metres
- Cable type: screened twisted pair



Type	Description	Code
XL 01	M2 - M2 local link (2 modules)	88 950 200
XL 05	4 solid state outputs	88 950 204

Adjacent extensions

- For XT 20 only (one adjacent extension per module)
- Communication using MODBUS or AS-i protocol (Slave module)
- 6 additional inputs/outputs



Type	Description	Code
XC 01	4 inputs 2 relay outputs 24 VDC	88 950 210
	4 inputs 2 relay outputs 24 VAC	88 950 211
	4 inputs 2 relay outputs 110 - 240 VAC	88 950 212
XC 02	AS-i exchange unit 24 VDC	88 950 213
XC 03	MODBUS exchange unit 24 VDC	88 950 214

Accessories

Type	Range	Precision	Code
Programming software on CD ROM			88 950 100
EEPROM memory module			88 950 101
PC-module link interface			88 950 102
Faceplate for front panel mounting EC 12 - SA 12			89 750 103
Faceplate for front panel mounting EC 20 - SA 20 - XT 20			89 750 109
Room temperature sensors	-10 → +40 °C	- 0,2 °C +1,2 °C (-10 → +40 °C)	89 750 150
Ventilation duct temperature sensors	-10 → +60 °C	- 0,2 °C +1,9 °C (-10 → +60 °C)	89 750 151
Outdoor temperature sensors	-10 → +40 °C	- 0,2 °C +1,2 °C (-10 → +40 °C)	89 750 152
Immersion/remote probe temperature sensors	-10 → +150 °C	- 0,2 °C +1,9 °C (-10 → +150 °C)	89 750 153

Dimensions

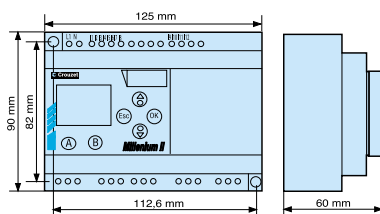

Size 20

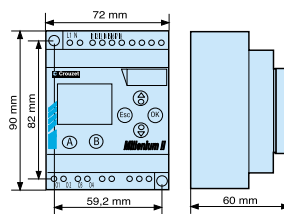

Size 12

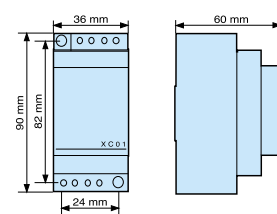

XC extensions

- Standard products
- Standard products, non stocked





2000 distribution points
throughout the world

> Belgium

Ets Crouzet SA
140 Avenue Roi Albert 1
1780 Wemmel
Tel. : +32 02 462 07 30
Fax : +32 02 461 00 23
E-mail : com-be@crouzet.com

12 sales outlets

> France

Crouzet Automatismes SA
2 rue du Docteur Abel - BP 59
26902 Valence Cedex 9 -
France
Tel. : +33 4 75 44 88 44
Fax : +33 4 75 55 98 03
E-mail : com-fr@crouzet.com

Customer Service
Technical sales information

N° Indigo 0 825 333 350

Fax N° Azur 0 810 610 102

3 production sites
400 sales outlets

> Germany

Crouzet GmbH
Otto-Hahn-Str. 3
D-40721 Hilden
Postfach 203
D-40702 Hilden
Tel. : +49 21 03 9 80-0
Fax : +49 21 03 9 80-2 00
E-mail : com-de@crouzet.com

Customer Service
Technical sales information

Automation Control
Tel. : +49 21 03 9 80-1 08 and 1 76
Fax : +49 21 03 9 80-2 50

Sensing
Tel. : +49 21 03 9 80-1 51 and 1 71
Fax : +49 21 03 9 80-2 50

Motors
Tel. : +49 21 03 9 80-1 51 and 1 71
Fax : +49 21 03 9 80-2 50

Pneumatic Control
Tel. : +49 21 03 9 80-1 08 and 1 76
Fax : +49 21 03 9 80-2 50

**Switching in harsh
environments**
Tel. : +49 21 03 9 80-1 23
Fax : +49 21 03 9 80-2 00

Gas burner control units
Tel. : +49 21 03 9 80-1 23
Fax : +49 21 03 9 80-2 00

Austria/Hungary
Hutweidengasse 22/2
A-1190 Wien
Tel. : +43 1 3685471
Fax : +43 1 3685472
60 sales outlets



Multi-technology
Know-how

> Hong-kong

Crouzet Asia Ltd
Suite 4512, 45/F, Tower 2
Metro Plaza
223 Hing Fong Road
Kwai Chung, N.T. - Hong Kong
Tel. : +852 2418 2118
Fax : +852 2424 7978
E-mail : com-hk@crouzet.com

14 sales outlets

> Italy

Crouzet Componenti s.r.l.
Via Brembo, 23
20139 Milano
Tel. : +39 02 57 306 611
Fax : +39 02 57 306 723
E-mail : com-it@crouzet.com

Subsidiaries

• **Turin**
Crouzet Componenti s.r.l.
Via Servais 112/B
10146 Torino
Tel. : +39 011 728 600
Fax : +39 011 723 564

• **Padoue**
Crouzet Componenti s.r.l.
Via Bachelet, 20
35010 Limena (PD)
Tel. : +39 049 884 1042
Fax : +39 049 884 1037

• **Bologne**
Crouzet Componenti s.r.l.
c/o Centergross
Blocco 1A n°222
40050 Funo di Argelato
(Bologna)
Tel. : +39 051 862 550
Fax : +39 051 862 810

3 agencies
116 sales outlets

> Mexico

Crouzet Mexicana SA
Aguiles Serdan n°416
San Felipe Hueyotlipan C.P
72030 - Puebla - Mexico
Tel. : +52 22 24 20 29/24 20 30
Fax : +52 22 24 21 47
E-mail : com-mx@crouzet.com

1 production site
35 sales outlets

> Spain

Crouzet, S.A
Rambla de Catalunya, 123
E-08008 Barcelona
Tel. : +34 93 415 38 15
Fax : +34 93 415 16 08
E-mail : es-consultas@crouzet.es

Customer Service
Technical sales information
Tel. : +34 93 292 21 44
Fax : +34 93 415 16 08

1 production site
92 sales outlets

> Sweden

Crouzet AB
Malmgardsvägen 63
Box 11183 - SE.100 61
Stockholm
Tel. : +46 8 556 02 200
Fax : +46 8 556 02 229
E-mail : crouzet@crouzet.se

Danmark
• **OEM-AUTOMATIC A/S**
Frydensbergvej 20,
Postboks 63 - DK-3660 Stenløse
Tel. : +45-47 17 35 00
Fax : +45-47 17 35 43

Norway
Elektronics -
Microswitches and Motors
• **OEM-AUTOMATIC A/S**
Tomtegata 20, Postboks 564
Brakerøya - NO-3002 Drammen
Tel. : +47-32 89 72 70
Fax : +47-32 89 72 80

Pneumatics
• **SR-AUTOMATION A/S**
Roykenveien 142, Postboks 406
NO-1373 Asker
Tel. : +47-66 78 77 80
Fax : +47-66 90 13 13

Finland
• **OEM-AUTOMATIC A/S**
Telekatu 8, PI 9 - FI-20101 Turku
Tel. : +358-2 4120 400
Fax : +358-2 4120 499

212 sales outlets

> Switzerland

Crouzet AG
Gewerbepark - Postfach 56
CH - 5506 Mägenwil
Tel. : +41 62 887 30 30
Fax : +41 62 887 30 40
E-mail : com-ch@crouzet.com

3 sales outlets

> The Netherlands

Crouzet BV
Industrieweg 17
2382 NR Zoeterwoude
Tel. : +31 71 581 20 30
Fax : +31 71 541 35 74
E-mail : com-nl@crouzet.com

86 sales outlets

> United Kingdom

Crouzet Ltd
Intec 3 - Wade Road
Basingstoke - Hampshire
RG24 8NE
Tel. : +44 (0)1256 318 900
Fax : +44 (0)1256 318 901
E-mail : info@crouzet.co.uk

40 sales outlets

> USA

Crouzet Corporation
3237 Commander Drive
Carrollton, Texas 75006
Tel. : +1 972 447-6700
Fax : +1 972 447-6786
E-mail : com-us@crouzet.com

406 sales outlets

> Other Countries

Crouzet Automatismes SA
2, rue du Docteur Abel - BP 59
26902 Valence Cedex 9 -
France
Tel. : +33 4 75 44 86 23
Fax : +33 4 75 44 81 05
Telex : 346340 F
E-mail : com-ex@crouzet.com

480 sales outlets

Warning:

The product information contained in this catalogue is given purely as information and does not constitute a representation, warranty or any form of contractual commitment. CROUZET Automatismes and its subsidiaries reserve the right to modify their products without notice. It is imperative that we should be consulted over any particular use or application of our products and it is the responsibility of the buyer to establish, particularly through all the appropriate tests, that the product is suitable for the use or application. Under no circumstances will our warranty apply, nor shall we be held responsible for any application (such as any modification, addition, deletion, use in conjunction with other electrical or electronic components, circuits or assemblies, or any other unsuitable material or substance) which has not been expressly agreed by us prior to the sale of our products.

More
than a standard



www.crouzetsales.com

Crouzet Sales, Gross Automation

1725 S. Johnson Rd., New Berlin, WI, 53146, 262-446-0000, Fax 262-446-0300, 877-268-3700

www.grossautomation.com